

4

3

2

1

ITEM NO.	PART NUMBER	DESCRIPTION	QTY.
2	96 BASE CAB AND OH	PLYWOOD SHELF, MILL FINISH C-TOP	1
3	TRIPLE TUBE TONGUE	54" CONFIGURATION	1
4	14K 2-5/16" COUPLER		1
7	12x72x84 WHEELBOX CABINET MEDICAL OPEN SHELVING	BRAVO BUILT SHELVING	2
8	3272 RV SIDE DOOR	RIGHT SIDE HINGE	1
9	3272 RV SIDE DOOR	LEFT SIDE HINGE	1
10	225/75R15	SILVER MOD WHEELS	5
12	Single Gang Surface Mount 110 Light Switch		1
13	12v Switch		4
14	RECESSED E-TRACK	LINEAR FEET	16
15	4' FLUORESCENT	SURFACE MOUNT	2
16	Standard Dome Light	12V	2
17	Scene K90	INCLUDES 2EA 3-POSITION 12V SWITCHES	4
19	NP Roof Vent		1
19	12V 3500LB TONGUE JACK		1
20	E-Z Up Emergency Response Pod		8
21	3000 LB CORNER POST DROP DOWN JACKS		2
22	WIRE & FRAME FOR A/C		1
23	12V KILL SWITCH		1
24	30A 8 SPACE PANEL AND CABLE HATCH 18AFF	36' LIFELINE FOR 50AMP MOTORBASE PLUG	1
25	110V INTERIOR RECEPT	SURFACE MOUNT	2
26	12V BATTERY W VENTED BOX		1
27	RECESSED SPARE TIRE COMPARTMENT		1
28	PARTITION WALL	4-1/2" THICK, FULL WIDTH, FULL HEIGHT	1
29	32x78 DOOR		1

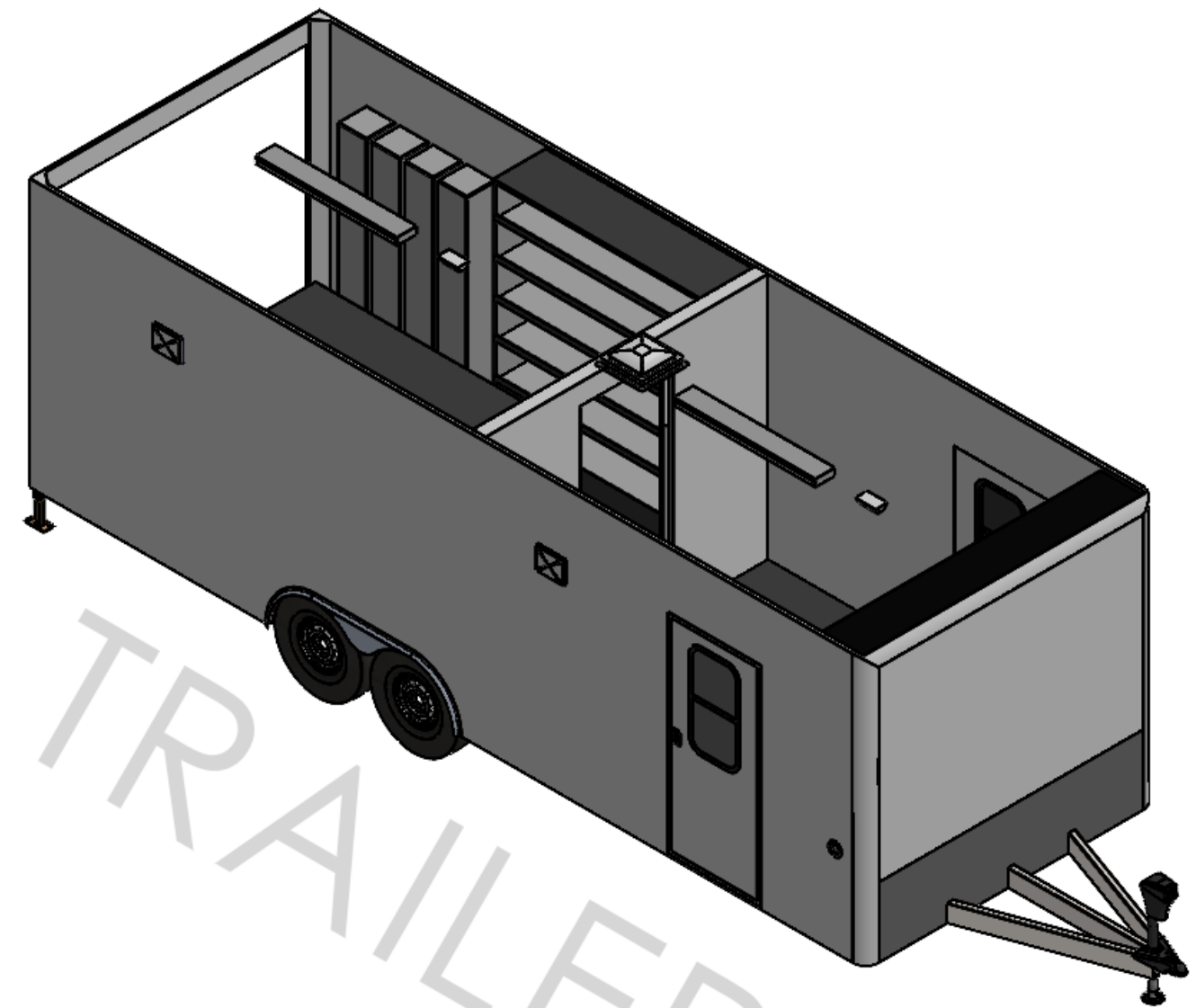

<p>19319 COUNTY ROAD 8, BRISTOL IN 46507 PHONE: 574.848.7500 - FAX: 574.848.7550</p> <p>PROPRIETARY AND CONFIDENTIAL</p> <p>THE INFORMATION CONTAINED IN THIS DRAWING IS THE SOLE PROPERTY OF BRAVO TRAILERS LLC. ANY REPRODUCTION IN PART OR AS A WHOLE WITHOUT THE WRITTEN PERMISSION OF BRAVO TRAILERS LLC IS PROHIBITED.</p>	UNLESS OTHERWISE SPECIFIED:	NAME	DATE	TITLE: ST8524TA3 MEDICAL UNIT		
	DIMENSIONS ARE IN INCHES TOLERANCES: FRACTIONAL ± 1/16" ANGULAR: MACH ± 1 BEND ± 2 TWO PLACE DECIMAL ± .06 THREE PLACE DECIMAL ± .063	DRAWN	B. LITRELL			4/6/2020
	INTERPRET GEOMETRIC TOLERANCING PER: ASME Y14.5-2009	CHECKED			SIZE	DWG. NO.
	MATERIAL	ENG APPR.			B	
FINISH	MFG APPR.			REV	A	
DO NOT SCALE DRAWING	Q.A.			SCALE: 1:42	WEIGHT:	
	COMMENTS:			SHEET 1 OF 5		

4

3

2

1

4

3

2

1

B

B

A

A

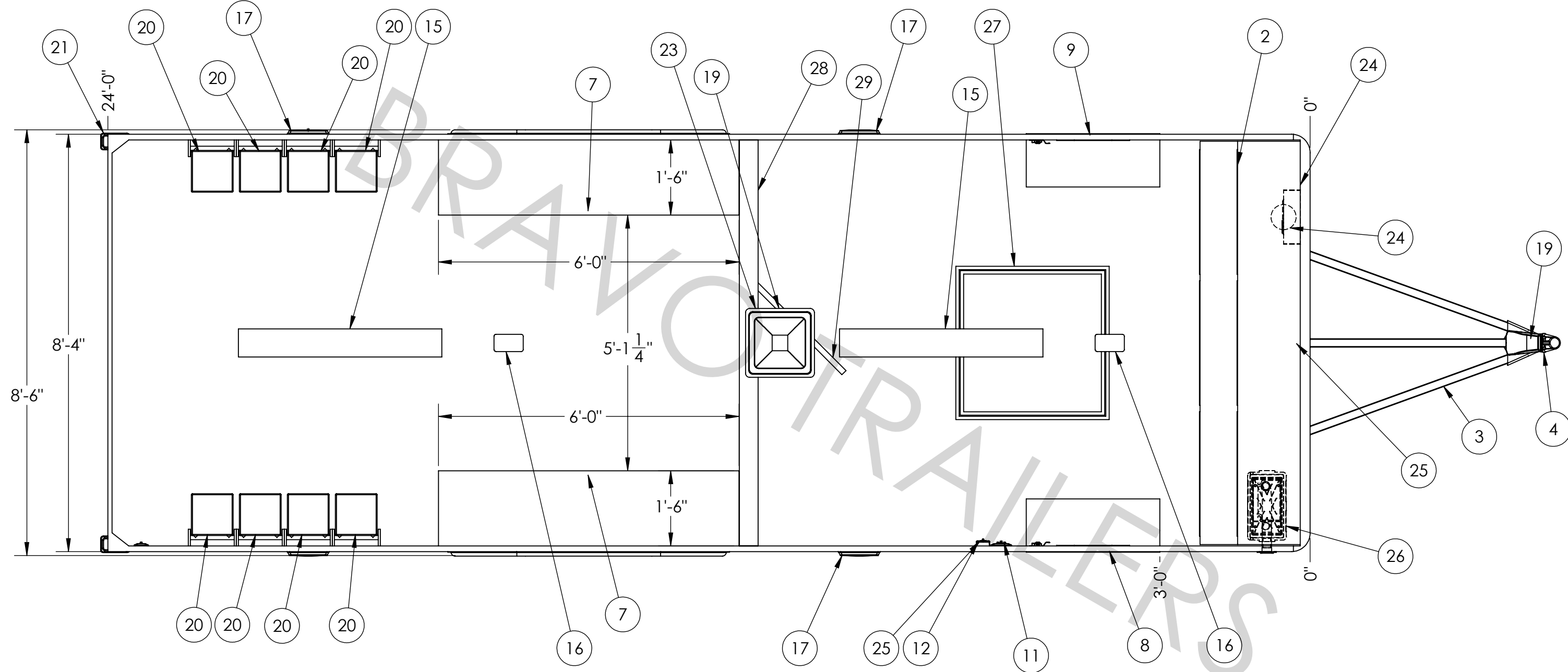

BRaVO
TRAILERS

19319 COUNTY ROAD 8, BRISTOL IN 46507
PHONE: 574.848.7500 - FAX: 574.848.7550

PROPRIETARY AND CONFIDENTIAL

THE INFORMATION CONTAINED IN THIS DRAWING IS THE SOLE PROPERTY OF BRAVO TRAILERS LLC. ANY REPRODUCTION IN PART OR AS A WHOLE WITHOUT THE WRITTEN PERMISSION OF BRAVO TRAILERS LLC IS PROHIBITED.

UNLESS OTHERWISE SPECIFIED:
DIMENSIONS ARE IN INCHES
TOLERANCES:
FRACTIONAL ± 1/16"
ANGULAR: MACH ± 1 BEND ± 2
TWO PLACE DECIMAL ± .06
THREE PLACE DECIMAL ± .063

INTERPRET GEOMETRIC TOLERANCING PER: ASME Y14.5-2009

MATERIAL

FINISH

DO NOT SCALE DRAWING

	NAME	DATE
DRAWN	B. LITRELL	4/6/2020
CHECKED		
ENG APPR.		
MFG APPR.		
Q.A.		
COMMENTS:		

TITLE: ST8524TA3 MEDICAL UNIT		
SIZE	DWG. NO.	REV
B		A
SCALE: 1:48	WEIGHT:	SHEET 2 OF 5

4

3

2

1

ROADSIDE

B

B

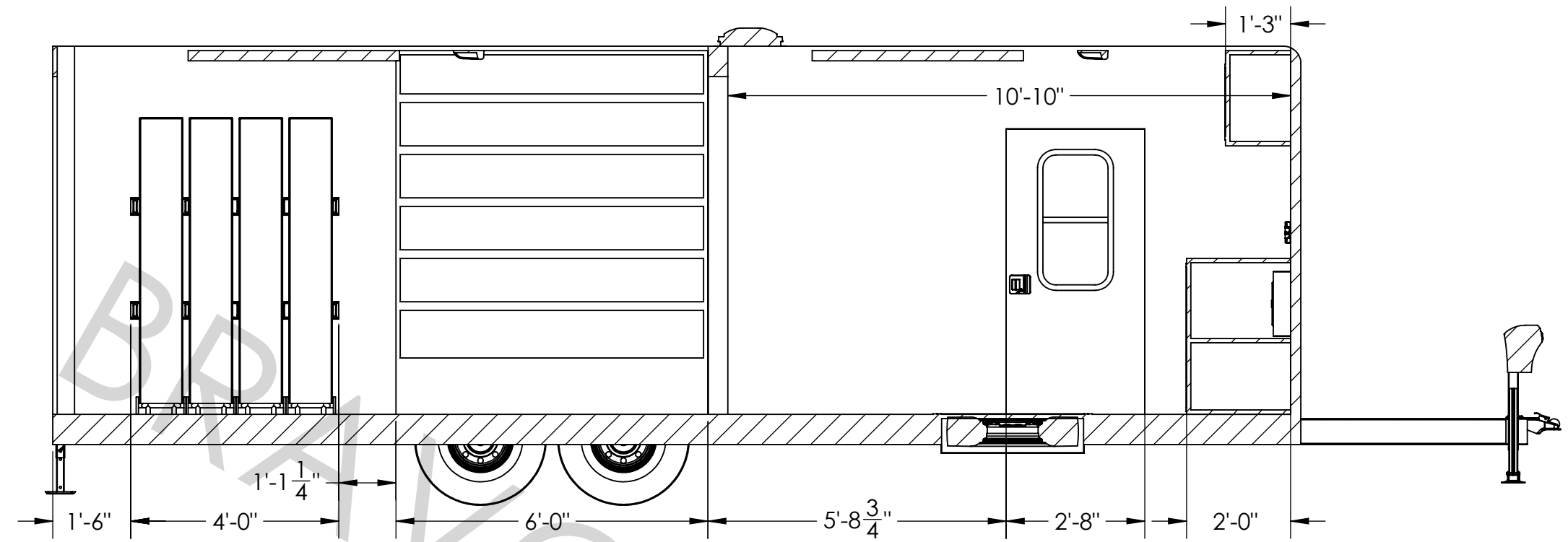

CURBSIDE

A

A

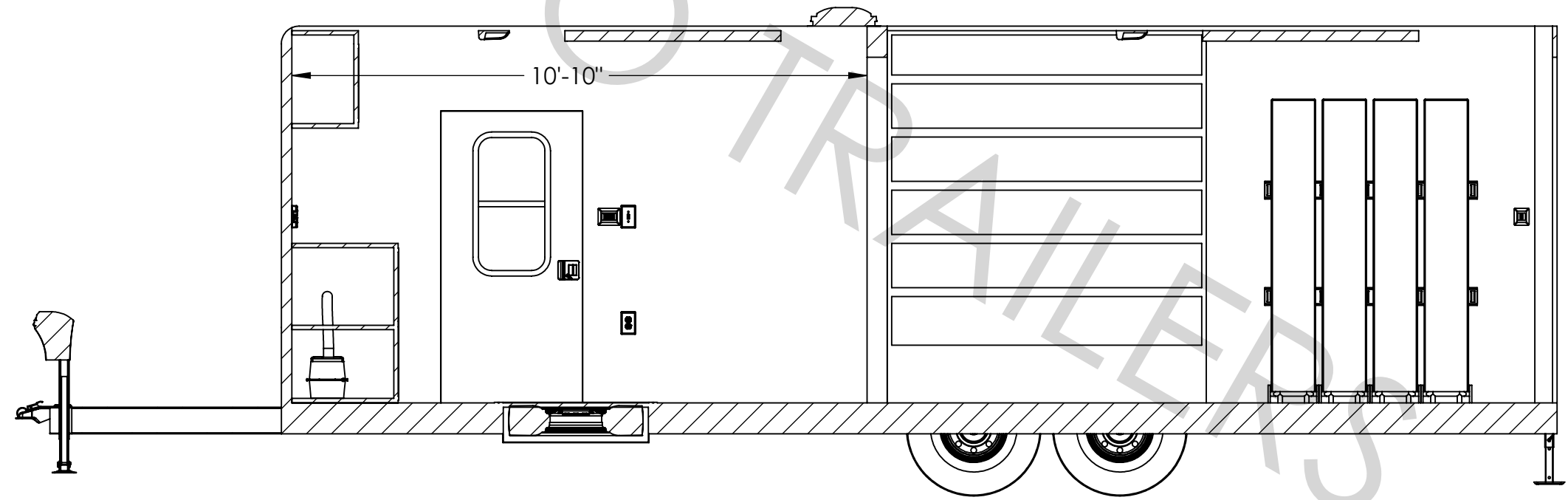

BRaVO
TRAILERS

19319 COUNTY ROAD 8, BRISTOL IN 46507
PHONE: 574.848.7500 - FAX: 574.848.7550

PROPRIETARY AND CONFIDENTIAL

THE INFORMATION CONTAINED IN THIS DRAWING IS THE SOLE PROPERTY OF BRAVO TRAILERS LLC. ANY REPRODUCTION IN PART OR AS A WHOLE WITHOUT THE WRITTEN PERMISSION OF BRAVO TRAILERS LLC IS PROHIBITED.

UNLESS OTHERWISE SPECIFIED:
DIMENSIONS ARE IN INCHES
TOLERANCES:
FRACTIONAL: ± 1/16"
ANGULAR: MACH ± 1 BEND ± 2
TWO PLACE DECIMAL ± .06
THREE PLACE DECIMAL ± .063

INTERPRET GEOMETRIC TOLERANCING PER: ASME Y14.5-2009

MATERIAL

FINISH

DO NOT SCALE DRAWING

	NAME	DATE
DRAWN	B. LITRELL	4/6/2020
CHECKED		
ENG APPR.		
MFG APPR.		
Q.A.		
COMMENTS:		

TITLE: ST8524TA3 MEDICAL UNIT		
SIZE	DWG. NO.	REV
B		A
SCALE: 1:32	WEIGHT:	SHEET 3 OF 5

4

3

2

1

4

3

2

1

B

B

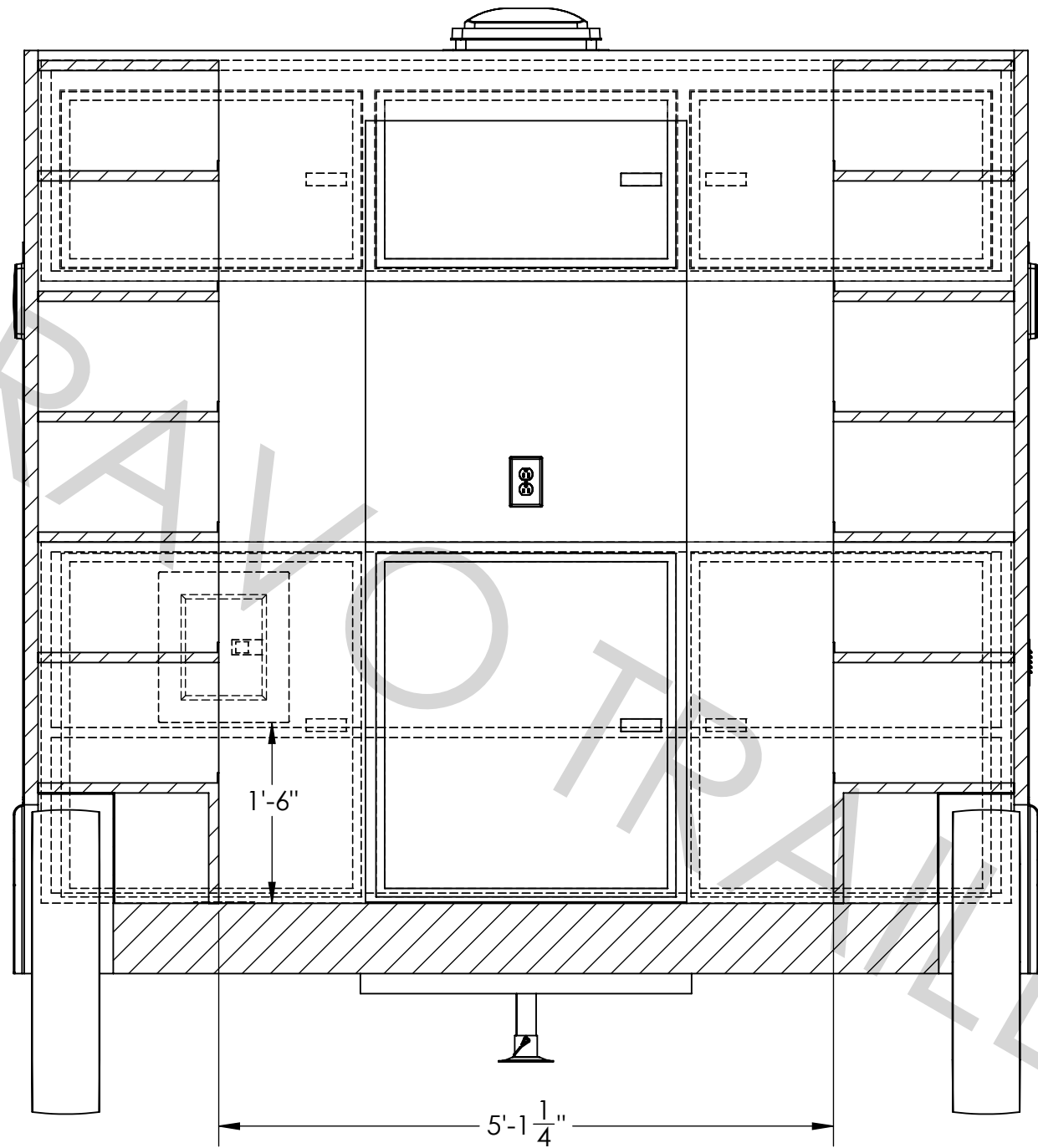

FONT WALL

A

A



19319 COUNTY ROAD 8, BRISTOL IN 46507
PHONE: 574.848.7500 - FAX: 574.848.7550

PROPRIETARY AND CONFIDENTIAL

THE INFORMATION CONTAINED IN THIS DRAWING IS THE SOLE PROPERTY OF BRAVO TRAILERS LLC. ANY REPRODUCTION IN PART OR AS A WHOLE WITHOUT THE WRITTEN PERMISSION OF BRAVO TRAILERS LLC IS PROHIBITED.

UNLESS OTHERWISE SPECIFIED:

DIMENSIONS ARE IN INCHES
 TOLERANCES:
 FRACTIONAL ± 1/16"
 ANGULAR: MACH ± 1 BEND ± 2
 TWO PLACE DECIMAL ± .06
 THREE PLACE DECIMAL ± .063

INTERPRET GEOMETRIC TOLERANCING PER: ASME Y14.5-2009

MATERIAL

FINISH

DO NOT SCALE DRAWING

	NAME	DATE
DRAWN	B. LITRELL	4/6/2020
CHECKED		
ENG APPR.		
MFG APPR.		
Q.A.		
COMMENTS:		

TITLE: ST8524TA3 MEDICAL UNIT		
SIZE	DWG. NO.	REV
B		A
SCALE: 1:16	WEIGHT:	SHEET 4 OF 5

4

3

2

1

4

3

2

1

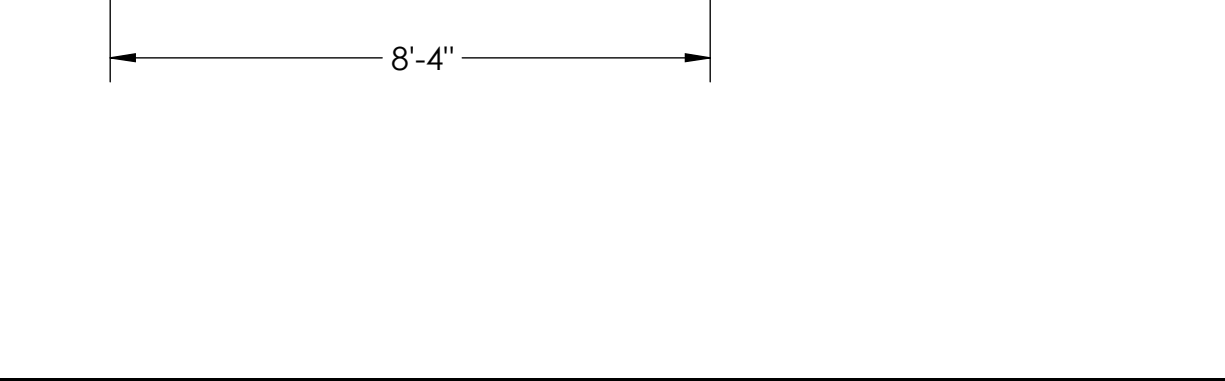
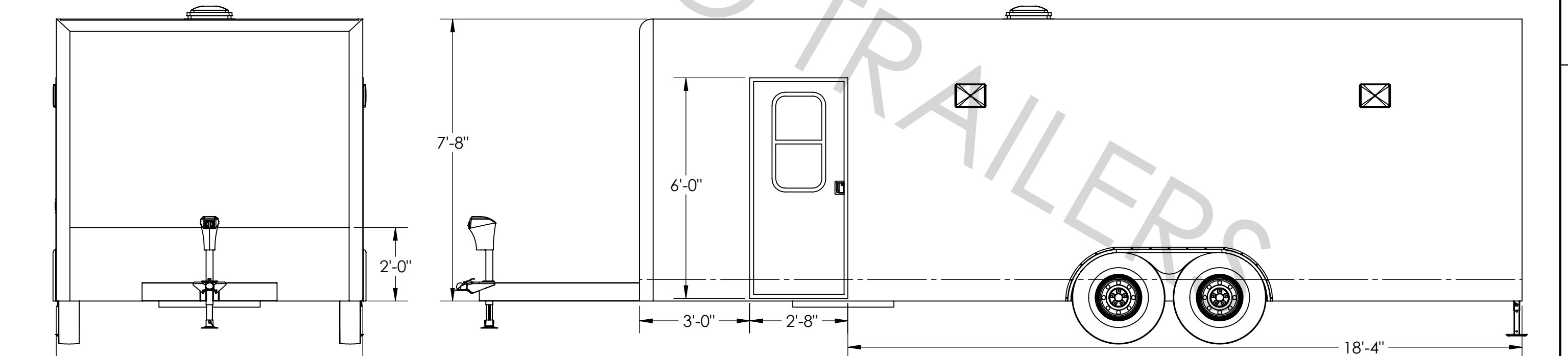
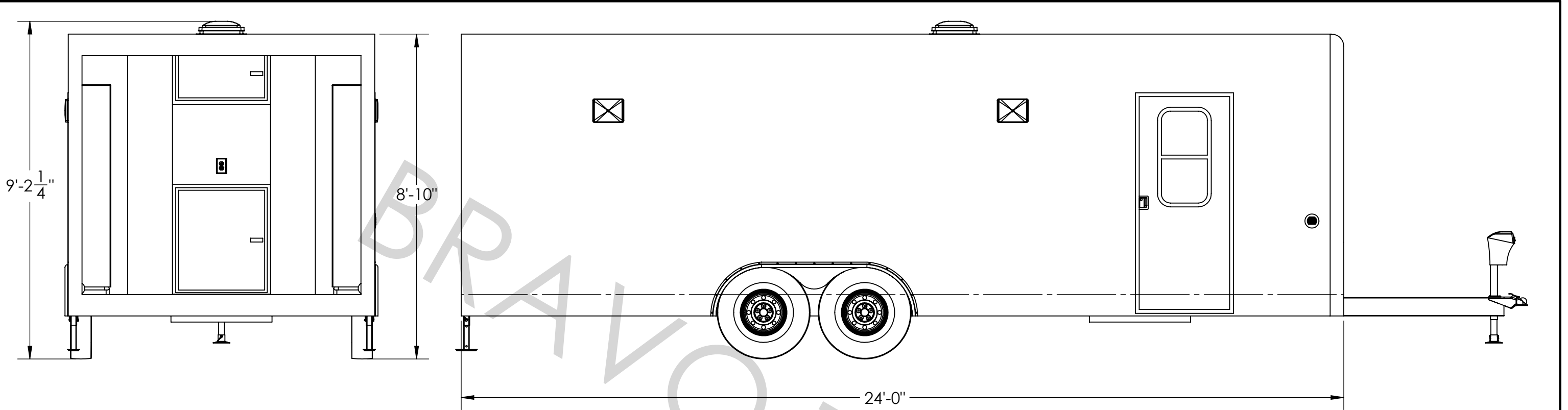

BRAVO TRAILERS
 19319 COUNTY ROAD 8, BRISTOL IN 46507
 PHONE: 574.848.7500 - FAX: 574.848.7550

PROPRIETARY AND CONFIDENTIAL
 THE INFORMATION CONTAINED IN THIS DRAWING IS THE SOLE PROPERTY OF BRAVO TRAILERS LLC. ANY REPRODUCTION IN PART OR AS A WHOLE WITHOUT THE WRITTEN PERMISSION OF BRAVO TRAILERS LLC IS PROHIBITED.

UNLESS OTHERWISE SPECIFIED:
 DIMENSIONS ARE IN INCHES
 TOLERANCES:
 FRACTIONAL ± 1/16"
 ANGULAR: MACH ± 1 BEND ± 2
 TWO PLACE DECIMAL ± .06
 THREE PLACE DECIMAL ± .063

INTERPRET GEOMETRIC TOLERANCING PER: ASME Y14.5-2009

MATERIAL

FINISH

DO NOT SCALE DRAWING

	NAME	DATE
DRAWN	B. LITRELL	4/6/2020
CHECKED		
ENG APPR.		
MFG APPR.		
Q.A.		
COMMENTS:		

TITLE: ST8524TA3 MEDICAL UNIT		
SIZE	DWG. NO.	REV
B		A
SCALE: 1:32	WEIGHT:	SHEET 5 OF 5

4

3

2

1